

- To test your independent learning skills, organisation and motivation you are to **complete** a free, online, Open University course called "Particle Physics".  
<https://www.open.edu/openlearn/science-maths-technology/particle-physics/content-section-0?active-tab=description-tab>  
 Or search "Open university free course particle physics"
- This course is pre-learning for a topic you will be taught from January of Year 12.
- You will need to **create a free account** before starting the course.
- The eight sections should take **no more than 40 minutes each** to complete. You may find that the course **takes between 5-6 hours** to complete in total. It is recommended that you do the sections over a period of few weeks as part of a routine.
- Each section has specific tasks, reading and assessments to do to meet appropriate outcomes and criteria.  
 The course is designed to consolidate and extend radioactivity learning from GCSE and challenge you towards new "A" level knowledge. This includes developing your maths skills, subject knowledge, analytical skills and communication skills.  
 After studying this course, you should be able to:
  - *recognise and name the six flavours of lepton and the six flavours of quark.*
  - *understand that all leptons and quarks have corresponding antiparticles*
  - *appreciate that quarks and antiquarks combine to form baryons, antibaryons and mesons.*
  - *write balanced strong interactions, understanding the role of gluons*
  - *write balanced weak interactions, understanding the role of W and Z bosons*
- **It is expected that you complete the course prior to starting in September.**
- **You must save the electronic certificate that you will earn by completing the course. You will be asked for it in September or you can send to us beforehand.**
- Finally, you will receive some GCSE exam questions to complete. **You will be asked for these in September.**

**Course offered:**

AQA GCE "A" Level Physics (7408)  
 Specification reference relating to this transition work is 3.2

**A level Physics team:**

Mr J. Davenport – Head of Science & Physics  
 Mrs. J. Owen  
 Mr. R. Santos

**If you have any questions or queries, contact [jdavenport@stjosephsmail.com](mailto:jdavenport@stjosephsmail.com)**

and you will get a reply as soon as possible.

If you are an SJC student already, you can send message on Teams.

Please note, due to school holidays, that it may be a few days before you receive a reply.

Specification: <https://filestore.aqa.org.uk/resources/physics/specifications/AQA-7407-7408-SP-2015.PDF>

A bit more background can be watched here:

<https://www.youtube.com/watch?v=HVxBdMxgVX0> <https://www.youtube.com/watch?v=WGWIT8SqXLM>

Textbook to purchase: <https://collins.co.uk/products/9780007590223>

**Q1.**

A TENS machine uses an electrical current to relieve pain.

**Figure 1** shows the electrodes of a TENS machine connected across an ankle.

**Figure 1**

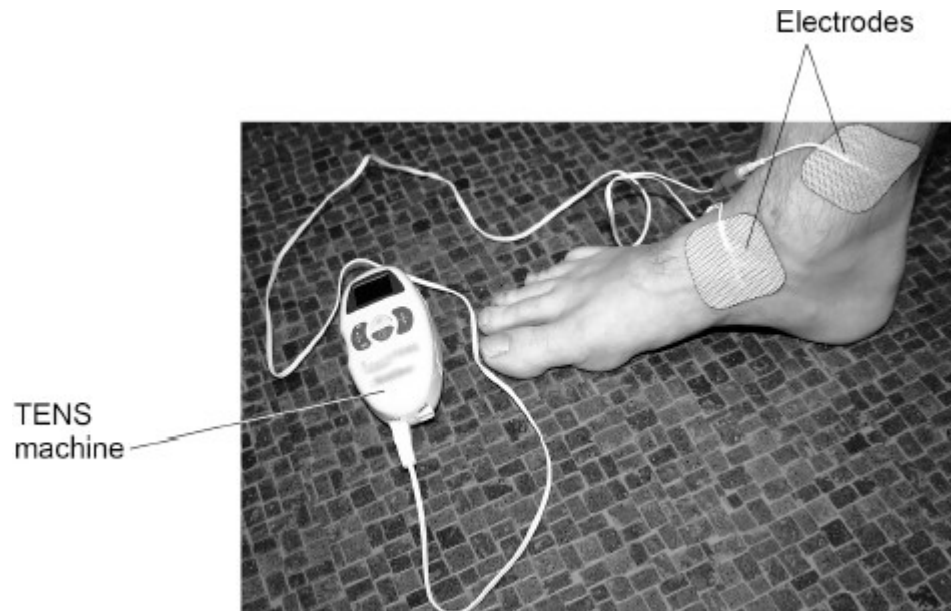

The maximum power of the TENS machine is 240 mW.

The potential difference across the battery in the TENS machine is 2.5 V.

Calculate the maximum current from the battery.

---

---

---

---

---

---

---

---

Maximum current = \_\_\_\_\_ A

(4)

**Q2.**

An air source heat pump transfers energy from the air outside a building to increase the temperature of the air inside the building.

The figure below shows an air source heat pump.

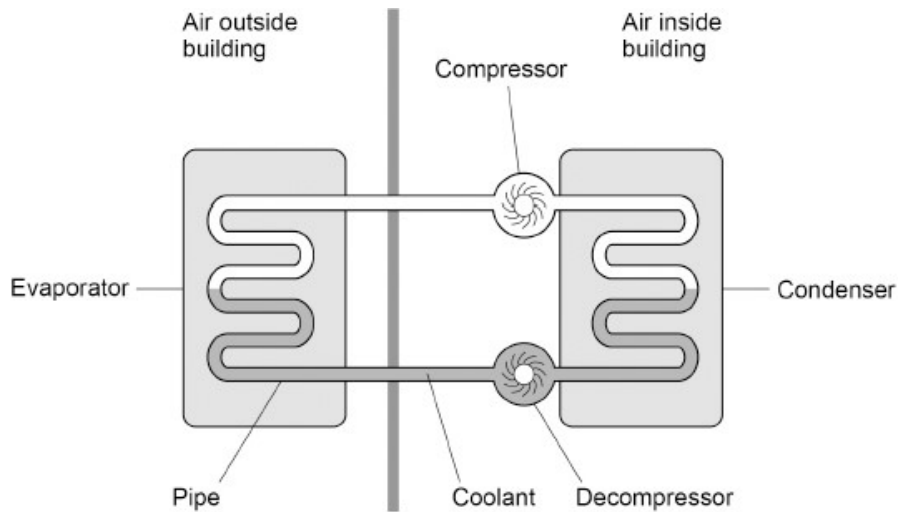

The compressor is connected to the mains electricity supply.  
The pipe in the heat pump contains a substance called coolant.

In the evaporator, energy is transferred from the air outside the building to the liquid coolant. The temperature of the coolant increases and it evaporates.

The condenser transfers energy from the coolant to the air in the building.

When the total energy input to the heat pump system is 1560 kJ the temperature of the air in the building increases from 11.6 °C to 22.1 °C.

The efficiency of the heat pump system is 87.5%.

The mass of the air inside the building is 125 kg.

Calculate the specific heat capacity of the air in the building.

Give your answer in standard form.

---

---

---

---

---

---

---

---

Specific heat capacity (standard form) = \_\_\_\_\_ J/kg °C

(6)

**Q3.**

**Figure 2** shows an electromagnet being used to separate iron and steel from non-magnetic metals.

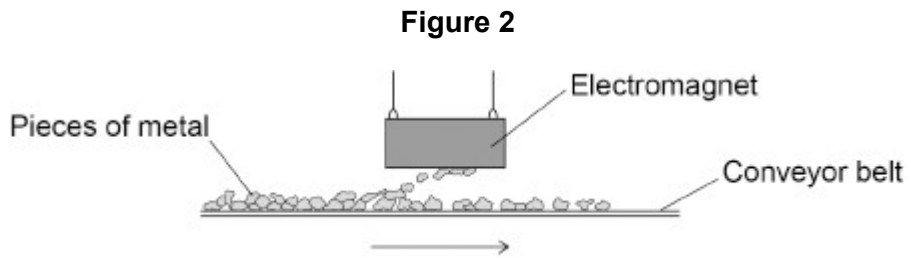

The conveyor belt that moves the pieces of metal is driven by an electric motor.

**Figure 3** shows a simple electric motor.

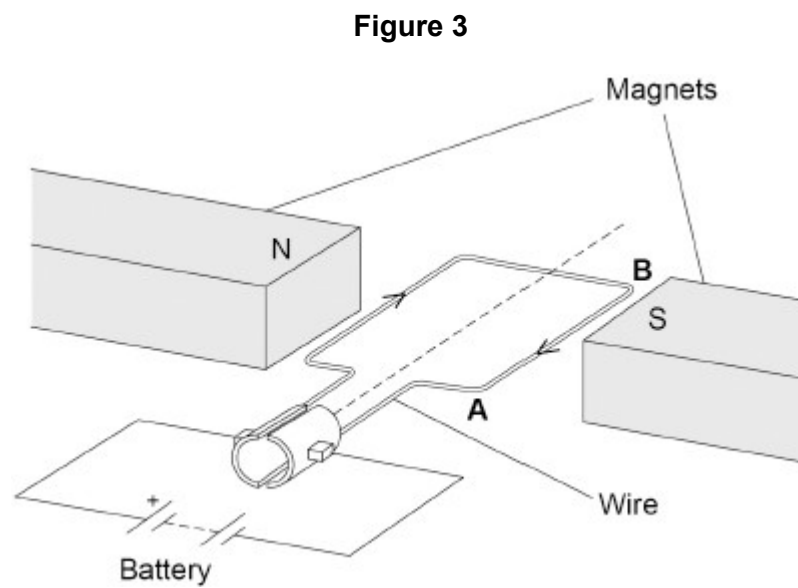

The length of the wire **AB** in the magnetic field is 120 mm.

There is a current of 4.0 A in the wire. The length of wire **AB** experiences a force of 0.36 N.

Calculate the magnetic flux density between the magnets. Give the unit.

---

---

---

---

---

---

---

Magnetic flux density = \_\_\_\_\_ Unit \_\_\_\_\_

(5)



**Q5.**

Ice cream is made by cooling a mixture of liquid ingredients until they freeze.

The diagram below shows a bowl used for making ice cream.

The walls of the bowl contain a liquid coolant.

The bowl is cooled to  $-20\text{ }^{\circ}\text{C}$  before the mixture is put in the bowl.

The bowl causes the mixture to cool down and freeze.

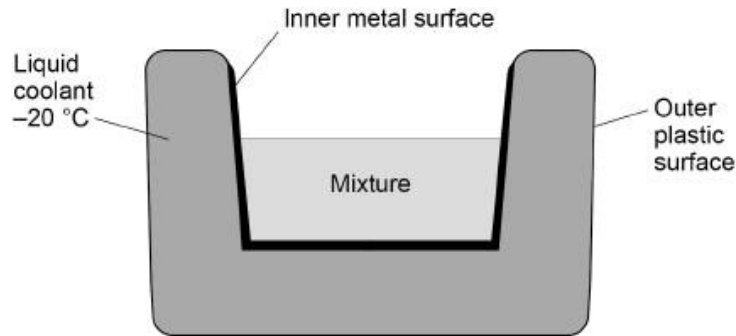

- (e) The initial temperature of the mixture was  $+20\text{ }^{\circ}\text{C}$ . The mixture froze at  $-1.5\text{ }^{\circ}\text{C}$ .

A total of 165 kJ of internal energy was transferred from the mixture to cool and freeze it.

specific heat capacity of the mixture =  $3500\text{ J/kg }^{\circ}\text{C}$

specific latent heat of fusion of the mixture =  $255\ 000\text{ J/kg}$

Calculate the mass of the mixture.

Give your answer to 2 significant figures.

---

---

---

---

---

---

---

---

---

---

---

Mass (2 significant figures) = \_\_\_\_\_ kg

(6)



**Q7.**

The speed limit on many roads in towns is 13.5 m/s.

Outside schools this speed limit is often **reduced by** one-third.

(c) **Figure 1** shows a car being driven at a constant speed past a speed camera.

**Figure 1**



The camera recorded two images of the car 0.70 s apart.

The car travelled 14 m between the two images being taken.

The maximum deceleration of the car is 6.25 m/s<sup>2</sup>

Calculate the minimum braking distance for the car at the speed it passed the speed camera.

---

---

---

---

---

---

---

---

---

---

Minimum braking distance = \_\_\_\_\_ m

(6)



**Q9.**

(a) **Figure 1** shows four newtonmeters.

Each newtonmeter contains a spring.

**Figure 1**

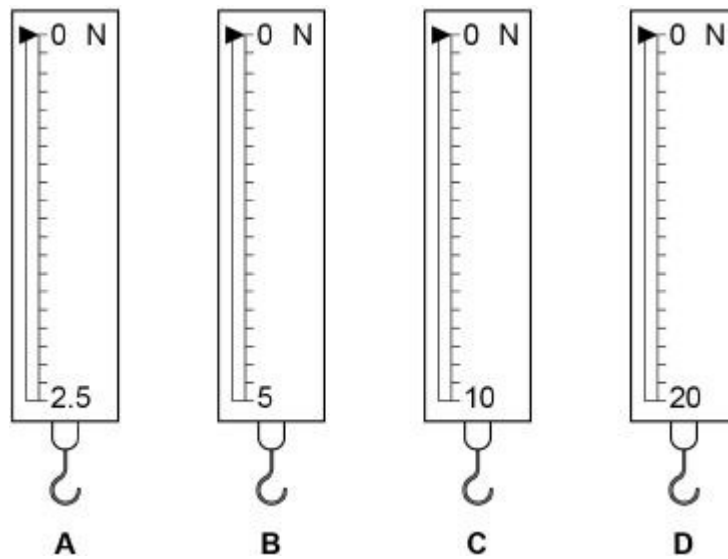

(c) A student hangs a weight on a newtonmeter.

The energy now stored in the spring in the newtonmeter is  $4.5 \times 10^{-2}$  J

The student then increases the weight on the newtonmeter by 2.0 N

Calculate the total extension of the spring.

Spring constant = 400 N/m

---

---

---

---

---

---

---

---

---

---

Total extension = \_\_\_\_\_ m

(6)

**Q10.**

A teacher used the equipment shown in the figure below to demonstrate the motor effect.

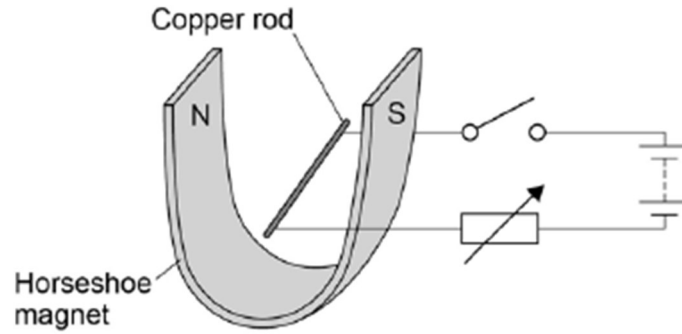

- (c) The copper rod in the figure above has a length of 7 cm and a mass of  $4 \times 10^{-4}$  kg.

When there is a current of 1.12 A the resultant force on the copper rod is 0 N.

Calculate the magnetic flux density.

Gravitational field strength = 9.8 N / kg

---

---

---

---

---

---

---

---

Magnetic flux density = \_\_\_\_\_ T

(5)

**Q11.**

- (a) When two objects collide, and no other forces act, then *conservation of momentum* applies.

- (i) What does the term conservation of momentum mean?

---

---

---

(2)

- (iii) Write, in words, the equation which you need to use to calculate momentum.

---

(1)

- (iv) The diagram shows a straight and horizontal runway and two trolleys, **X** and **Y**, which can move on the runway.

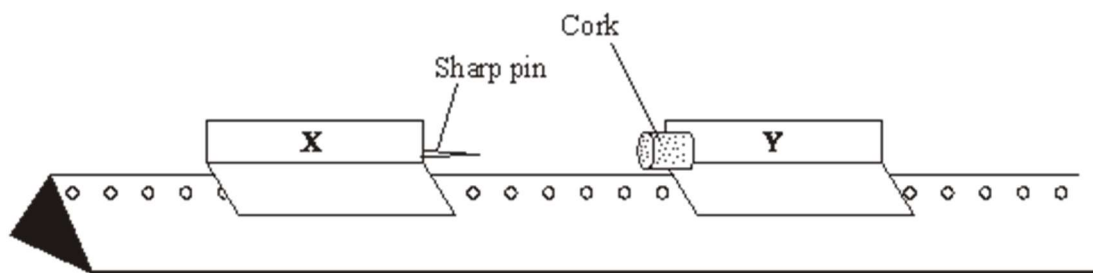

**X** has a mass of 0.2 kg and its velocity is 1.2 m/s to the right. **Y** has a mass of 0.1 kg and is stationary. When **X** collides with **Y** they stick together.

Calculate the velocity of the trolleys after the collision.

Show clearly how you work out your answer and give the unit and direction.

---

---

---

---

Velocity of the trolleys = \_\_\_\_\_

(5)

**Q13.**

'**SPEED KILLS**' - was the heading of an advertising campaign. The scientific reason for this is that energy is transferred from the vehicle to the person it knocks down.

- (b) A car and its passengers have a mass of 1200 kg. It is travelling at 12 m/s.
- (i) Calculate the increase in kinetic energy when the car increases its speed to 18 m/s.

Show clearly how you work out your answer and give the unit.

---

---

---

---

---

---

---

---

---

---

Increase in kinetic energy = \_\_\_\_\_

(5)

**Q14.**

A car which is moving has kinetic energy.

The faster a car goes, the more kinetic energy it has. The kinetic energy of this car was 472 500 J when travelling at 30 m/s.

Calculate the total mass of the car.

Show clearly how you work out your answer and give the unit.

---

---

---

---

---

---

---

---

Mass of the car = \_\_\_\_\_

(Total 5 marks)

**Q15.**

(b) The diagram shows a car and a lorry about to collide.

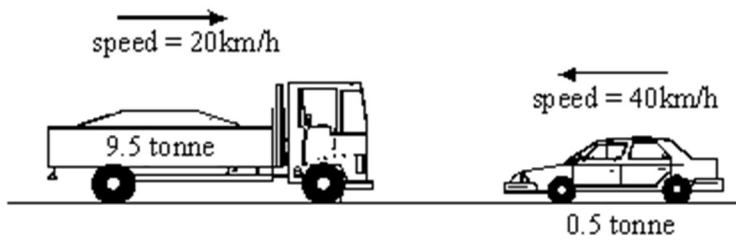

When they collide, the two vehicles become tightly locked together.

(i) Calculate the speed of the vehicles immediately after the collision.

(Show your working. There is no need to change to standard units.)

---

---

---

---

---

---

---

Answer \_\_\_\_\_ km/h

(6)



**Q17.**

The camera in a mobile phone uses an LED to provide light when taking a photograph.

A student investigated how the potential difference across an LED varies with the current in it.

**Figure 1** shows the circuit used.

**Figure 1**

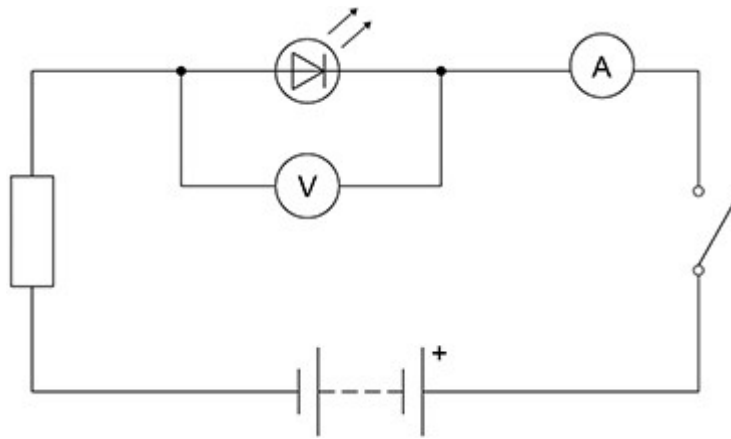

- (b) The student changed the circuit so that the LED emitted light.

The current in the circuit was 290 mA

The power of the LED was 0.98 W

Calculate the potential difference across the LED.

Use the Physics Equations Sheet.

Give your answer to 2 significant figures.

---

---

---

---

---

---

---

---

---

---

Potential difference (2 significant figures) = \_\_\_\_\_ V

(5)

A traditional camera uses a flash unit to provide light.

**Figure 2** shows a flash unit on a traditional camera.

**Figure 2**



- (d) When the flash unit is used there is a mean potential difference of 200 V across the fluorescent tube.

The flash of light lasts for  $2.8 \times 10^{-4}$  s

1.4 J of energy is transferred.

Calculate the mean current.

Use the Physics Equations Sheet.

---

---

---

---

---

---

---

---

---

---

Mean current = \_\_\_\_\_ A

(6)

(Total 14 marks)





## Mark schemes

### Q1.

(a)  $240 \text{ mW} = 0.24 \text{ W}$

1

$$0.24 = 2.5 \times I$$

*allow a correct substitution using an incorrectly/not converted value of power*

1

$$I = \frac{0.24}{2.5}$$

*allow a correct re-arrangement using an incorrectly/not converted value of power*

1

$$I = 0.096 \text{ (A)}$$

*allow a correct calculation using an incorrectly/not converted value of power*

1

**Q2.**

(e)  $0.875 = \frac{\text{useful output energy transfer}}{1\,560\,000}$   
*allow a correct substitution using incorrectly/not converted values of efficiency and/or energy*

1

useful output energy transfer = 1 365 000(J)

*this answer only*

*the equation*

$$\text{efficiency} = \frac{\text{useful output energy transfer}}{\text{total input energy transfer}}$$

*must have been used to score subsequent marks*

1

$$1\,365\,000 = 125 \times c \times (22.1 - 11.6)$$

*allow a correct substitution using their calculated value of useful output energy*

1

$$c = \frac{1\,365\,000}{125 \times 10.5}$$

*allow a correct re-arrangement using their value of useful output energy*

1

$$c = 1040 \text{ (J/kg } ^\circ\text{C)}$$

*allow a correct calculation using with their value of useful output energy*

1

$$c = 1.04 \times 10^3 \text{ (J/kg } ^\circ\text{C)}$$

*this mark can only be awarded for a calculation using the correct equations*

1

**Q3.**

(f)  $L = 0.120 \text{ m}$

1

$$0.36 = B \times 4.0 \times 0.120$$

*allow a correct substitution of an incorrectly / not converted value of L*

1

$$B = \frac{0.36}{(4.0 \times 0.120)}$$

*allow a correct rearrangement using an incorrectly / not converted value of L*

1

$$B = 0.75$$

*allow a correct calculation using an incorrectly / not converted value of L*

1

T

1

**Q4.**

(b)  $\Delta v = (25.5 - 5.5) \times 330$   
*allow 6600 m/s*

1

$$a = \frac{((25.5 \times 330) - (5.5 \times 330))}{300}$$

*allow a correct substitution using incorrectly / not converted values of u and v*

1

$$a = 22 \text{ m/s}^2$$

*allow a correct calculation using incorrectly / not converted values of u and v*

*a =  $\Delta v / t$  must have been used to score subsequent marks*

1

$$m = 630\,000 / 22$$

*allow a correct substitution using an incorrectly calculated value of a*

1

$$m = 28636.36 \text{ (kg)}$$

*allow a correct calculation using an incorrectly calculated value of a*

1

$$m = 29000 \text{ (kg)}$$

*this mark can only be awarded for a calculation using the correct equations*

1

[11]

**Q5.**

(e)  $165 \text{ kJ} = 165000 \text{ J}$

1

$$\Delta E = m \times 3500 \times 21.5$$

**and**

$$\Delta E = m \times 255000$$

1

$$165000 = 75250 m + 255000 m$$

**or**

$$165000 = 330250 m$$

*this mark may be awarded if E is incorrectly/not converted*

1

$$m = \frac{165000}{75250 + 255000}$$

**or**

*this mark may be awarded if E is incorrectly/not converted*

1

$$m = \frac{165000}{330250}$$

*allow an answer consistent with their value of E*

$$m = 0.499621 \text{ (kg)}$$

1

$$m = 0.50 \text{ (kg)}$$

*this answer only*

*If no marks awarded other than the first marking point:*

**either**

$$165\,000 = m \times 3500 \times 21.5 \text{ scores } \mathbf{1} \text{ mark}$$

$$m = 2.192\dots \text{ scores } \mathbf{1} \text{ mark}$$

$$m = 2.2 \text{ (kg) scores } \mathbf{1} \text{ mark.}$$

*these marks may be awarded if E is incorrectly/not converted*

**or**

$$165\,000 = m \times 255\,000 \text{ scores } \mathbf{1} \text{ mark}$$

$$m = 0.647 \text{ scores } \mathbf{1} \text{ mark}$$

$$m = 0.65\text{kg scores } \mathbf{1} \text{ mark.}$$

*these marks may be awarded if E is incorrectly/not converted*

1

[14]

**Q6.**

(b)  $E = 770 \times 0.14$

*allow  $E = 107.8$  (J)*

1

extension = 0.070m

1

$107.8 = 0.5 \times k \times 0.070^2$

*this mark may be awarded if extension is incorrectly/not converted and/or if the efficiency equation has not been applied*

1

$k = 2 \times \frac{107.8}{0.070^2}$

*this mark may be awarded if extension is incorrectly/not converted and/or if the efficiency equation has not been applied*

1

$k = 44\,000$  (N/m)

*this mark may be awarded if extension is incorrectly/not converted**this mark may not be awarded if the efficiency equation has not been applied*

1

**[8]****Q7.**

(c)  $14 = v \times 0.70$

1

$v = \frac{14}{0.70}$

1

$v = 20$  (m/s)

1

$0^2 - 20^2 = 2 \times (-6.25) \times s$

1

$s = \frac{20^2}{(2 \times 6.25)}$

*ignore minus signs throughout*

1

$s = 32$  (m)

1

**Q8.**

(b)

*an answer of 300 000 (kg) scores 5 marks*

$$a = \frac{(10-80)}{28}$$

allow  $a = \frac{(80-10)}{28}$

1

$$a = (-)2.5 \text{ (m/s}^2\text{)}$$

*a valid equation must have been used to calculate a to score subsequent marks*

1

$$(-) 750\,000 = m \times (-)2.5$$

*allow a correct substitution using their calculated value of a*

1

$$m = \frac{(-)750\,000}{(-)2.5}$$

*allow a correct rearrangement using their calculated value of a*

1

$$m = 300\,000 \text{ (kg)}$$

*allow a correct calculation using their calculated value of a*

1

[9]

### Q9.

(c)  $4.5 \times 10^{-2} = 0.5 \times 400 \times e^2$

*this mark may be awarded if the standard form value is incorrectly converted*

1

$$e = \sqrt{\frac{4.5 \times 10^{-2}}{0.5 \times 400}}$$

*this mark may be awarded if the standard form value is incorrectly converted*

allow  $e^2 = \frac{4.5 \times 10^{-2}}{0.5 \times 400}$

1

$$e = 0.015 \text{ (m)}$$

*this answer only*

1

$$2.0 = 400 \times e$$

1

$$e = 0.005 \text{ (m)}$$

*this answer only*

1

$$0.015 + 0.005 = 0.02 \text{ (m)}$$

*allow their initial extension + their additional extension correctly calculated*

1

**or**

$$4.5 \times 10^{-2} = 0.5 \times 400 \times e^2 \text{ (1)}$$

*this mark may be awarded if the standard form value is incorrectly converted*

$$e = \sqrt{\frac{4.5 \times 10^{-2}}{0.5 \times 400}} \text{ (1)}$$

*this mark may be awarded if the standard form value is incorrectly converted*

$$\text{allow } e^2 = \frac{4.5 \times 10^{-2}}{0.5 \times 400}$$

$$e = 0.015 \text{ (m) (1)}$$

*this answer only*

$$F = 400 \times 0.015$$

$$F = 6 \text{ (N) (1)}$$

*allow an answer of  $400 \times$  their calculated value of  $e$*

$$\text{total force} = 6 + 2$$

$$8 = 400 \times e \text{ (1)}$$

*allow an answer that is consistent with their calculated value of  $e$*

$$e = 0.02 \text{ (m) (1)}$$

*an answer of 0.02 (m) gains 6 marks*

[10]

**Q10.**

(c)  $W = 9.8 \times 4 \times 10^{-4} = 3.92 \times 10^{-3}$

1

conversion of the length 7cm to 0.07m

1

$$3.92 \times 10^{-3} = B \times 1.12 \times 0.07$$

1

$$B = 3.92 \times 10^{-3} / 0.0784$$

1

$$B = 0.05 \text{ (T)}$$

1

*allow 0.05 (T) without working shown for the 5 calculation marks*

[10]

**Q11.**

- (a) (i) **either**  
the momentum in a particular direction after (the collision) is the same as the momentum in that direction before (the collision)

*accept 'momentum before equals momentum after' for 1 mark*

**or total** momentum after (the collision) equals the **total** momentum before (the collision) (2)

*accept 'momentum before equals momentum after' for 1 mark*

2  
1

- (iii) momentum = mass  $\times$  velocity **or** any correctly transposed version

*accept momentum = mass  $\times$  speed*

*accept  $p = mv$*

*do **not** accept momentum =  $ms$*

*or  $M = mv$*

1

- (iv) 0.8

*if answer 0.8 not given, any **two** for (1) each:*

*momentum of **X** =  $0.2 \times 1.2$*

*= momentum of **X and Y** after impact*

*=  $0.3 \times v$  **or**  $(0.1 + 0.2) \times v$*

3

m/s

1

to the right

**Q13.**

(b) (i)

Note: this calculation requires candidates to show clearly how they work out their answer

k.e.  $\frac{1}{2} mv^2$

accept evidence of equation

1

86 400 (J) at 12 m/s

accept  $\frac{1}{2} \times 1200 \times 12^2$  or 86.4 KJ

1

194 400 (J) at 18 m/s

accept  $\frac{1}{2} \times 1200 \times 18^2$  or 194.4KJ

1

increase in k.e. = 108 000

NB 10800 = 0 marks

*N.B. if no working at all then max 3 for a correct numerical answer*

1

joules or J

accept 108 kilojoules or kJ

1

**Q14.**

1050

4

kg

if answer incorrect then kinetic energy =  $\frac{1}{2} mv^2$  or  
accept indication by correct substitution for 1 mark  
accept 900 for 1 mark

accept  $m = \frac{2KE}{v^2}$  or indication by correct substitution for 1 mark

1

[5]

**Q15.**

- (b) (i) any evidence of concept of momentum or mass  $\times$  speed  
(or velocity) in words or figures e.g.  $9.5 \times 20$  **or**  $0.5 \times 40$   
*gains 1 mark*

**but** correct values for momentum of lorry and car  
i.e. 190 and 20 [ignore units]

*gains 2 marks*

**but** initial momentum correctly calculated  
170 or  $190 - 20$

*gains 3 marks*

THEN

evidence when calculating final speed of  
idea that momentum is conserved  
use of combined mass

*each gain 1 mark*

**but**

17 [or  $0.1 \times$  figure for initial momentum]  
(NB direction not required)

*gains 3 marks*

6

[10]

**Q16.**

(b)  $4.9 = 0.5 \times k \times 0.056^2$

1

$$k = \frac{2 \times 4.9}{0.056^2} = 3125 = 3125$$

1

$$8.1 = 0.5 \times 3125 \times e^2$$

*allow a correct substitution of an incorrectly calculated value of k*

1

$$e = \sqrt{\left(\frac{2 \times 8.1}{3125}\right)}$$

*allow a correct re-arrangement using an incorrectly calculated value of k*

1

$$e = 0.072 \text{ (m)}$$

*allow an answer consistent with their calculated value of k*

1

**Q17.**

(b)  $290 \text{ mA} = 0.29 \text{ A}$

1

$$0.98 = V \times 0.29$$

*allow a correct substitution of an incorrectly / not converted current*

1

$$V = \frac{0.98}{0.29}$$

*allow a correct calculation using an incorrectly / not converted current*

1

$$V = 3.379$$

1

$$V = 3.4 \text{ (V)}$$

1

(d) **either**

$$1.4 = 200 \times Q$$

*an answer of 25(A) scores 6 marks*

1

$$Q = \frac{1.4}{200}$$

1

$$Q = 0.0070 \text{ (C)}$$

1

$$0.0070 = I \times 2.8 \times 10^{-4}$$

*allow a correct substitution of their calculated value of Q*

1

$$I = \frac{0.0070}{2.8 \times 10^{-4}}$$

*allow a correct re-arrangement using their value of Q*

1

$$I = 25 \text{ (A)}$$

*allow an answer consistent with their value of Q*

1

**OR**

$$1.4 = P \times 2.8 \times 10^{-4} \text{ (1)}$$

$$P = \frac{1.4}{2.8 \times 10^{-4}} \text{ (1)}$$

$$P = 5000 \text{ (W) (1)}$$

$$5000 = 200 \times I \text{ (1)}$$

*allow a correct substitution of their calculated value of Q*

$$I = \frac{5000}{200} \text{ (1)}$$

*allow a correct re-arrangement using their value of Q*

$$I = 25 \text{ (A) (1)}$$

*allow an answer consistent with their value of Q*

[14]